



Doc. No. NDP 497M-08

## MAINTENANCE MANUAL

# ***GLOBAL SERIES***

**Air-Operated Double Diaphragm Pumps**

**G15 Series**

## **WARNING**



- For your own safety, be sure to read these procedures carefully before performing maintenance on this product. After reading this document, be sure to keep it handy for future reference.

These maintenance manuals cover what you should know about maintenance of the Yamada G15 Series Diaphragm Pumps.

This edition is based on the standards for the February 2023 production run. Remember, the specifications are always subject to change; therefore, some of the information in this edition may not apply to new specifications.

### **Warnings and Cautions**

For safe use of this product, be sure to note the following: In this document, warnings and cautions are indicated by symbols. These symbols are for those who will operate this product and for those who will be nearby, for safe operation and for prevention of personal injury and property damage. The following warning and caution symbols have the meanings described below. Be sure to remember their meanings.



**WARNING** : If you ignore the warning described and operate the product in an manner, there is danger of serious bodily injury or death.



**CAUTION** : If you ignore the caution described and operate the product in an improper manner, there is danger of personal injury or property damage.

Furthermore, to indicate the type of danger and damage, the following symbols are also used along with those mentioned above:



This symbol indicates a DON'T, and will be accompanied by an explanation on something you must not do.



This symbol indicates a DO, and will be accompanied by instructions on something you must do in a certain situation.

## **WARNING**



- Before starting maintenance work, cut off the feed air and clean the pump. If air pressure or residue remain in the pump, there is danger of explosion, or possible poisoning resulting in serious injury or death if chemicals adhere to the skin or are accidentally swallowed. (For details on cleaning the pump, refer to Chapter 6 of the Operation Manual.)



- When replacing parts, be sure to use the recommended genuine parts or Equivalents. Use of other parts may cause a malfunction of the product. (Refer to Parts list the separate sheets.)

## **CAUTION**



- When it is instructed that special tools must be used, be sure to use the specified tools. Otherwise, the pump may be damaged.



- Refer to "10.1 Specifications" in the Operation Manual. Also, remember that the pump is heavy, and extreme care must be taken when lifting it.

# Table of Contents

·Warnings and Cautions	
·Table of Contents	
<b>1.Principles of operation</b> .....	1
<b>2. Maintenance and Tools</b>	
2.1 Maintenance .....	1
2.2 General tools .....	1
2.3 Special tools .....	1
2.4 Misc. ....	1
<b>3.Ordering Replacement parts</b> .....	1
<b>4.Balls, Valve seats</b>	
4.1 Removal .....	2
4.2 Inspection .....	4
4.3 Installation.....	4
<b>5.Diaphragm and Center rod</b>	
5.1 Removal .....	5
5.2 Inspection .....	7
5.3 Installation.....	7
<b>6.Guide bush</b>	
6.1 Removal .....	8
6.2 Inspection .....	9
6.3 Installation.....	9
<b>7.Spool assembly and Sleeve</b>	
7.1 Removal .....	10
7.2 Inspection .....	12
7.3 Installation.....	12
<b>8.Retightening of Tie rods</b> .....	13

## 1. Principles of operation

There are two diaphragms fixed to the center rod, one at each end. When compressed air is supplied to air chamber b (right side, see Fig.1.1), the center rod moves to the right, the material in material chamber B is pushed out, and at the same time material is sucked into material chamber A.

When the center rod is moved full-stroke to the right, the air switch valve is switched, compressed air is sent to air chamber a (left side, see Fig.1.2), and the center rod moves to the left. The material in material chamber A is pushed out, and at the same time material is sucked into material chamber B.

Through repetition of this operation, material is repeatedly taken in and discharged out.

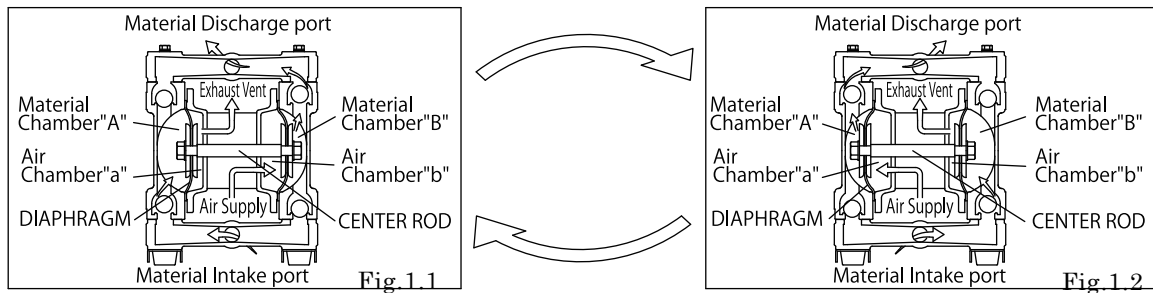

## 2. Maintenance and Tools

### 2.1 Maintenance

Since APDD (air powered double diaphragm pumps) can be used in many different applications varying in pressure, temperature, viscosity corrosiveness, and other properties, it is best to do a periodic inspection of the pump. Recording data on each installed pump during inspections will also serve as a record for any future maintenance. Typical maintenance involves inspection of the air valve, diaphragms, balls, valve seats and O-rings. BOTH diaphragms should be replaced if they show any sign of wear, abrading, or cracking. Refer to this manual for acceptable measurable working tolerances on other wearing components.

### 2.2 General tools

- Socket wrenches                    10 mm (A\_, S\_, P\_, V\_) , 12 mm (P\_, V\_) ,  
   13 mm (A\_, S\_) , 17 mm (A\_, S\_)
- Open-end wrenches                10 mm (A\_, S\_) , 12 mm (P\_, V\_) , 13 mm (A\_, S\_) ,  
   17 mm (A\_, S\_) , 22 mm (P\_, V\_)
- Hexagonal box wrenches        5 mm
- Phillips head screw driver (P\_, V\_)
- Pliers (P\_, V\_)

### 2.3 Special tools (sold separately)

- Cap remover (A\_, S\_)
  - Purpose: Removing the guide bush and cap

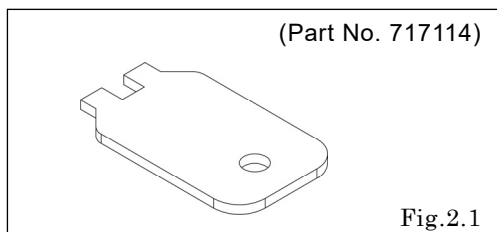

Fig.2.1

- Sleeve remover
  - Purpose: For removing sleeves

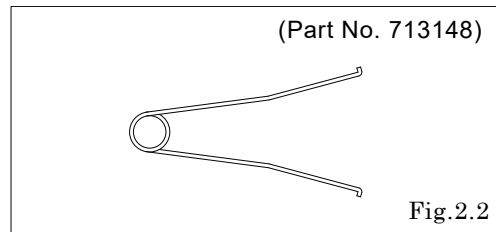

Fig.2.2

### 2.4 Misc.

- Assembly oil                    Turbine oil none addition class 1(equivalent ISO VG32 grade)
- Grease                            Urea grease grade (NLGI) No.2
- Thread locking agent Equivalent to LOCTITE® 222 (S\_)
- Thread locking agent Equivalent to LOCTITE® 243 (P\_, V\_)

## 3. Ordering Replacement parts

For accurate and speedy shipment of parts, be sure to order the right parts for your model to distributor. Indicate the part numbers, descriptions, and quantities.

## 4. Balls, Valve seats

### 4.1 Removal

#### ■ A\_, S\_ Type

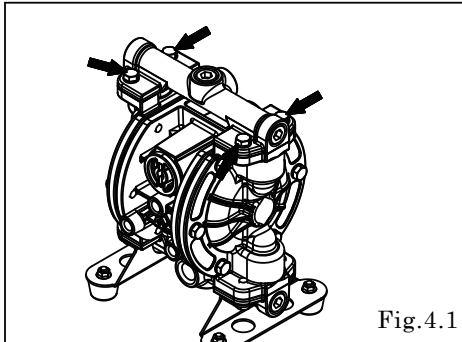

- Remove 4 mounting bolts from upper manifold and remove the manifold. [Fig.4.1]

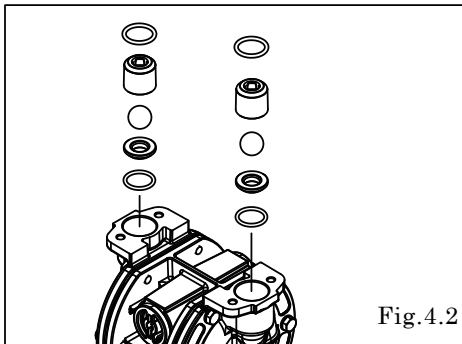

- Remove the O ring, valve stopper, ball, valve seat. [Fig.4.2]

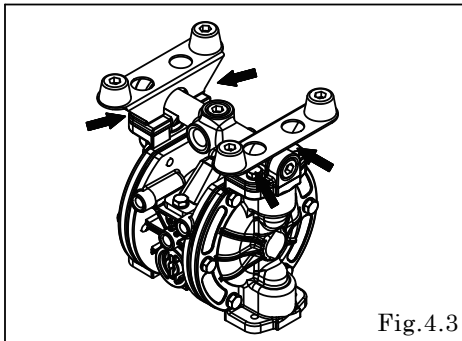

- Turn over the main body assembly. [Fig.4.3]
- Remove 4 mounting bolts from lower manifold and remove the base and the manifold. [Fig.4.3]

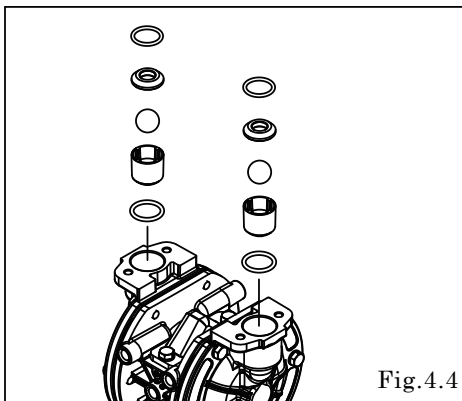

- Remove the O ring, valve seat, ball, valve stopper. [Fig.4.4]

■ P\_, V\_ Type

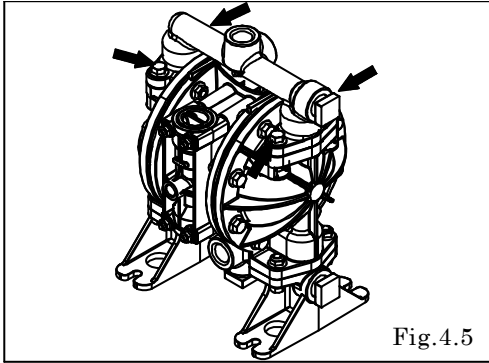

- Remove 4 mounting bolts from upper manifold A and remove the manifold A. [Fig.4.5]

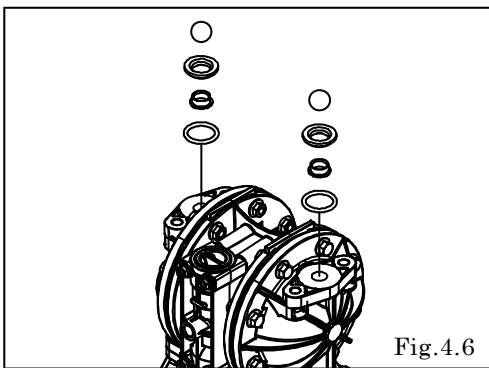

- Remove the Ball, valve seat A, valve seat B, O ring. [Fig.4.6]

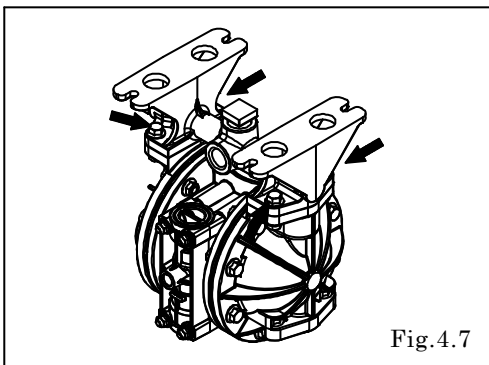

- Turn over the main body assembly. [Fig.4.7]
- Remove 4 mounting bolts from lower manifold B and remove the manifold B. [Fig.4.7]

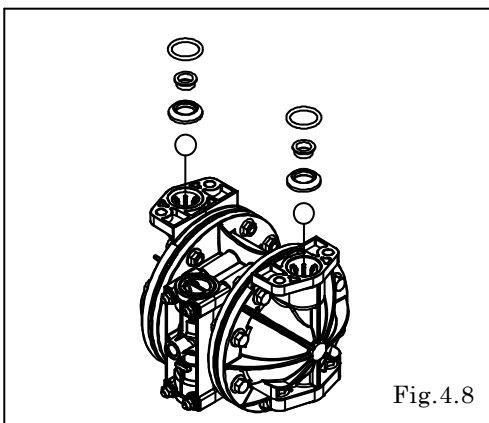

- Remove the O ring, valve seat B, valve seat A, ball. [Fig.4.8]

## 4.2 Inspection

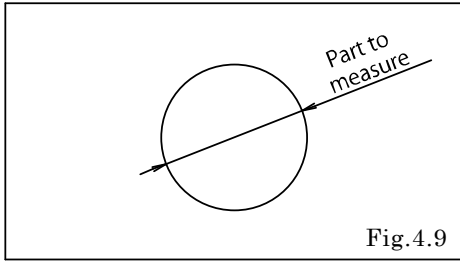

- Ball [Fig.4.9]  
Measure the outside diameter, and if it is outside the usable range, replace the ball.

### Usable range of Ball

$S\phi 0.669 - S\phi 0.760$  in { $S\phi 17.0 - S\phi 19.3$  mm}

- O ring  
If O ring is worn out or cracked, replace it.  
Replace the PTFE O ring regardless of its condition.

### ■ A\_, S\_ Type

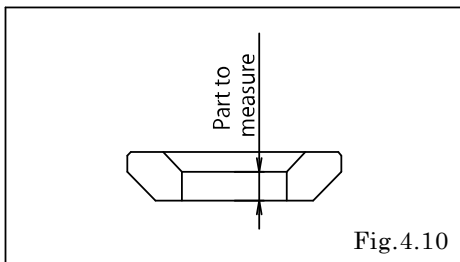

- Valve seat [Fig.4.10]  
Measure the dimension shown at left, and if it is outside the usable range, replace the valve seat.

### Usable range of Valve seat

0.102 - 0.225 in {2.6 - 5.7 mm}

### ■ P\_, V\_ Type

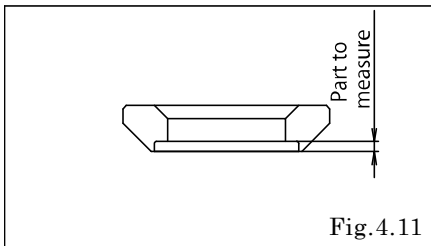

- Valve seat A [Fig.4.11]  
Measure the dimension shown at left, and if it is outside the usable range, replace the valve seat A.

### Usable range of Valve seat A

0.055 - 0.071 in {1.4 - 1.8 mm}

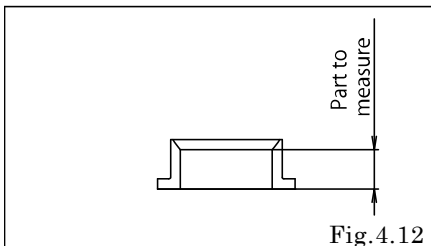

- Valve seat B [Fig.4.12]  
Measure the dimension shown at left, and if it is outside the usable range, replace the valve seat B.

### Usable range of Valve seat B

0.177 - 0.256 in {4.5 - 6.5 mm}

## 4.3 Installation

For installation, see [Exploded View] on the separate sheet and install in the reverse order of disassembly.

### ■ P\_, V\_ Type

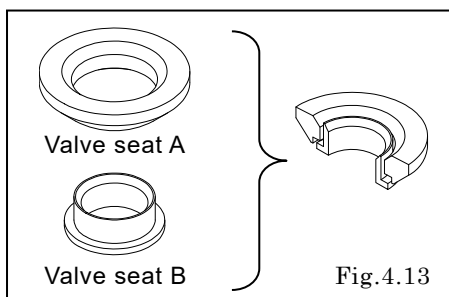

### Tightening torque for manifold retainer bolts or nuts

AN, AH, AS, AT SN, SH, SS, ST	105 in-lbf {12 N-m}
P_, V_	89 in-lbf {10 N-m}

### <NOTE>

- Make sure there is no dust on the seal surface and the seal is not damaged.
- Valve seat A and B should be used as a set. (Please do not forget to put the Valve seat B into A). [Fig.4.13]

## 5. Diaphragm and Center rod

### 5.1 Removal

#### ■ A\_, S\_ Type

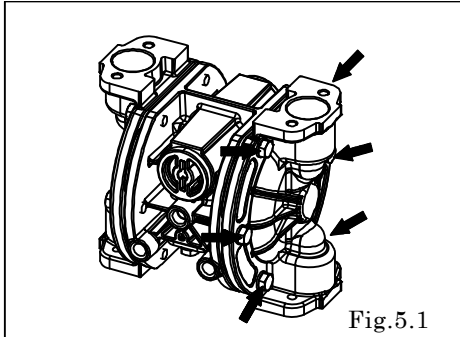

- Remove the O ring, valve stopper, ball, valve seat (see “4.1 Removal”).
- Remove the 12 retainer bolts from the out chamber, and remove the out chamber. [Fig.5.1]

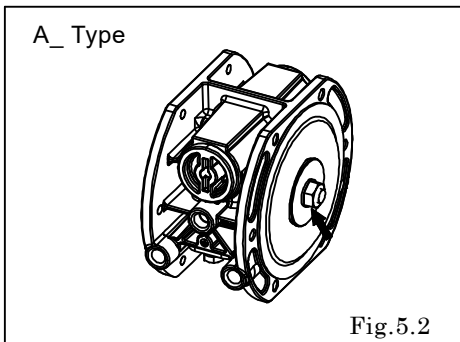

- After the nuts on one side have been removed, remove the center disk and diaphragm. [Fig.5.2]
- Remove the diaphragm, center disk and center rod from the opposite side of the main body.

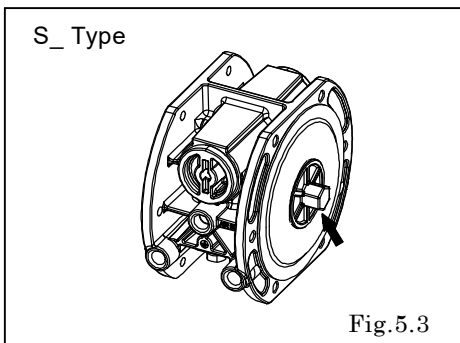

- After the center disk on one side have been removed, remove the center disk and diaphragm. [Fig.5.3]
- Remove the diaphragm, center disk and center rod from the opposite side of the main body.

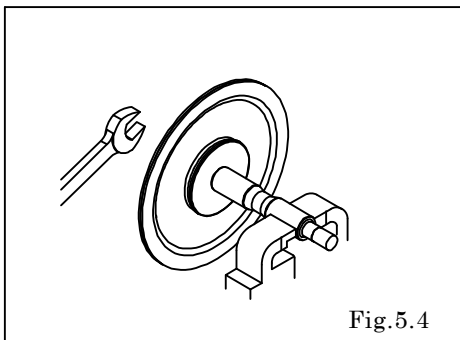

- Put the cloth between the vise and the center rod to prevent the part get scratched. [Fig.5.4]
- Fix the center rod, and then;
  - A\_ type: remove the nut
  - S\_ type: remove the center disk
- Remove the coned disk spring (only A\_ Type), center disk and diaphragm from center rod.



## ■ P\_, V\_ Type

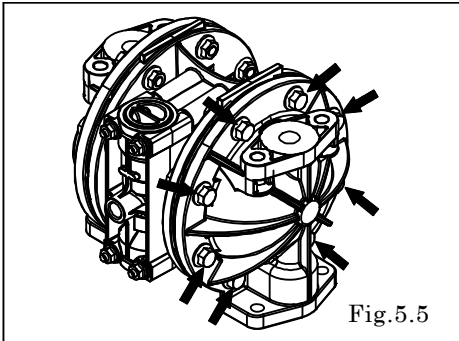

- Remove the ball, valve seat A, valve seat B, O ring. (see “4.1 Removal”).
- Remove the 16 retainer bolts from the out chamber, and remove the out chamber. [Fig.5.5]

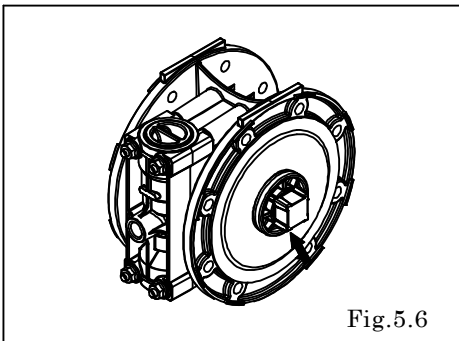

- When removing the center disks from both edges of the center rod, please turn the disks to the loosening direction with spanners (22 mm) and so on. [Fig5.6]
- Please remove one of the center disks, the diaphragms, and the backup diaphragms (limited to PT and VT series) from one side; then take the other center disk on the other side and the center rod from the pump body.

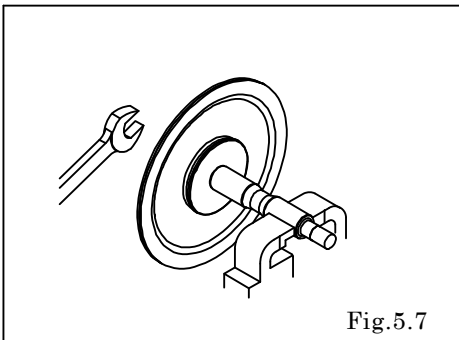

- Put the cloth between the vise and the center rod to prevent the part get scratched.
- Fix the center rod, and remove the center disk. [Fig.5.7]
- Remove the diaphragm, backup diaphragm (only PT, VT Type) and center disk.

## 5.2 Inspection

- Diaphragm
  - Please visually check whether there are any wears or damages on the diaphragms. Please replace it for a new one if you find one.
  - Please replace it together with the back-up diaphragm. (only PT, VT Type)
- Center rod [Fig.5.8]
  - Measure the diameter, and if it is outside the usable range, replace the center rod.

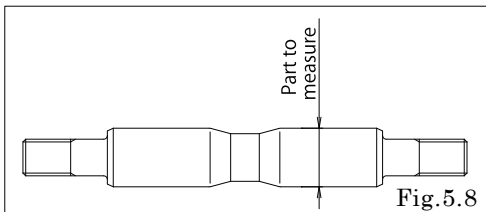

Usable range of center rod
$\varnothing 0.6280 - \varnothing 0.6299$ in { $\varnothing 15.95 - \varnothing 16.00$ mm}

## 5.3 Installation

For installation, see [Exploded View] on the separate sheet and install in the reverse order of disassembly.

### ■ A\_ , S\_ Type

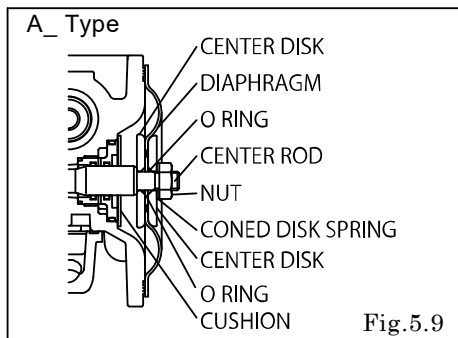

- Apply grease to the center rod, and insert it into the main body.
- Keep the convex side to the outside for diaphragm.
- For the model with PTFE diaphragm, put the O rings into both side of the diaphragms. (cf. Fig.5.9, Fig.5.10).
- A\_ type: Tighten the nuts.
- S\_ type: Apply screw glue on the thread of center rod, then tighten the center disks.
- Assemble the out chamber. Bolts should not be fully tightened at this point.
- Place the pump on flat surface, stand the pump upright and tighten all the bolts fully.

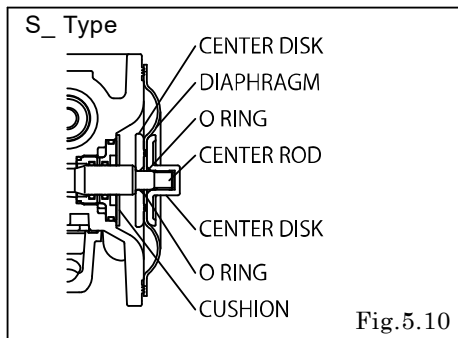

Tightening torque for center rod and out chamber	
Center rod	Out chamber
$160$ in-lbf { $18$ N-m}	$105$ in-lbf { $12$ N-m}

<NOTE>

- Make sure there is no dust on the seal surface in order to prevent seal damaged.
- Replace the PTFE O ring by new one.
- Tighten the bolts that balance should be equal from both side on diagonal line with even torque.

## ■ P\_, V\_ Type

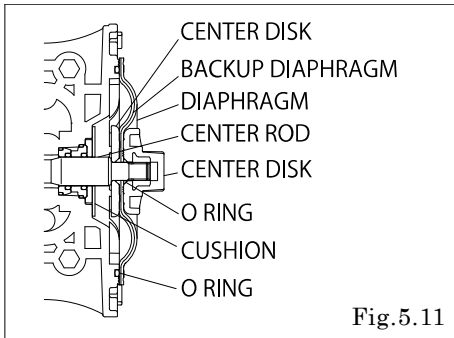

- Apply grease to the center rod, and insert it into the main body.
- PTFE Diaphragm model : Put the backup diaphragm before PTFE diaphragm, and O ring after PTFE diaphragm. (cf. Fig.5.11)
- Keep the convex side to the outside for diaphragm and backup diaphragm.
- Apply screw glue on the thread of center rod, then tighten the center disk.
- Put the body on a flat surface, and ensure the out chambers on both sides are aligned parallel to each other before temporarily fixing the bolts. After that, tighten all the bolts.

Tightening torque for center rod and out chamber

Center rod	Out chamber
177 in-lbf {20 N-m}	89 in-lbf {10 N-m}

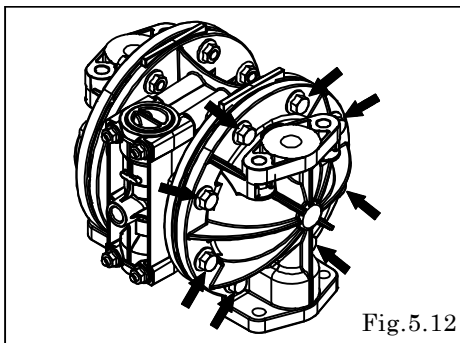

### <NOTE>

- Make sure there is no dust on the seal surface in order to prevent seal damaged.
- Replace the PTFE O ring by new one.
- When installing the out chambers, please tighten the bolts in diagonal pattern. At this point, please firstly fasten all the bolts evenly to a certain extent, and repeat a few fastening rounds with the even force before finally tightening to the specified torque. [Fig.5.12]
- When tightening the two (our four on both sides) bolts in upper position of the out chamber, please use a torque wrench with a spanner-shaped edge.

## 6. Guide bush

### 6.1 Removal

#### ■ A\_, S\_ Type

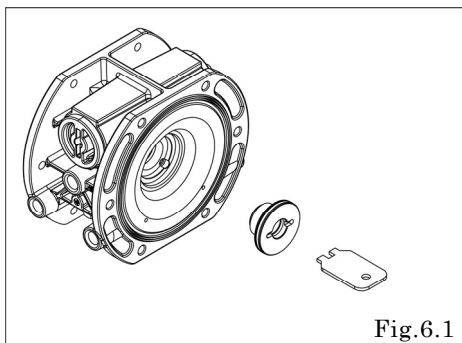

- Remove the diaphragm and center rod etc. (see “5.1 Removal”).
- Remove the guide bushing with Cap remover (Special tool: 717114) [Fig. 6.1]

#### ■ P\_, V\_ Type

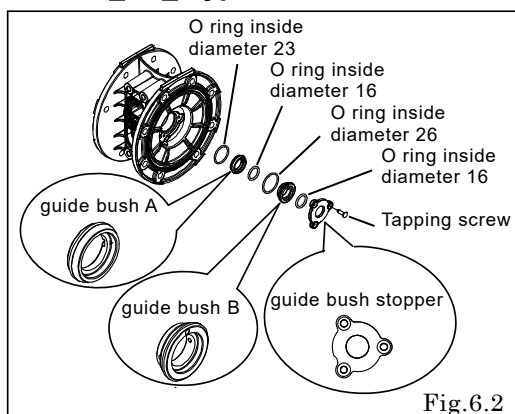

- Remove the diaphragm and center rod etc. (see “5.1 Removal”).
- Remove the tapping screw fixing the guide bush stopper and remove the guide bush A, guide bush B and O ring. [Fig.6.2]

## 6.2 Inspection

### ■ A\_, S\_ Type

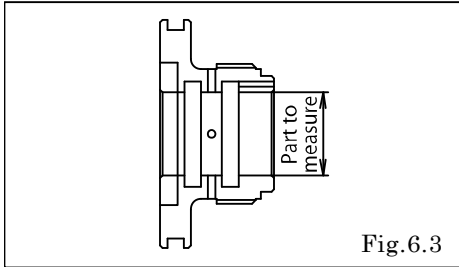

Fig. 6.3

- O ring  
If the O ring is worn out or cracked, replace it.

- Guide bush [Fig.6.3]  
Measure the inside diameter, and if it is outside the usable range, replace the guide.

Usable range of guide
$\varnothing 0.6299 - \varnothing 0.6378$ in { $\varnothing 16.0 - \varnothing 16.2$ mm}

### ■ P\_, V\_ Type

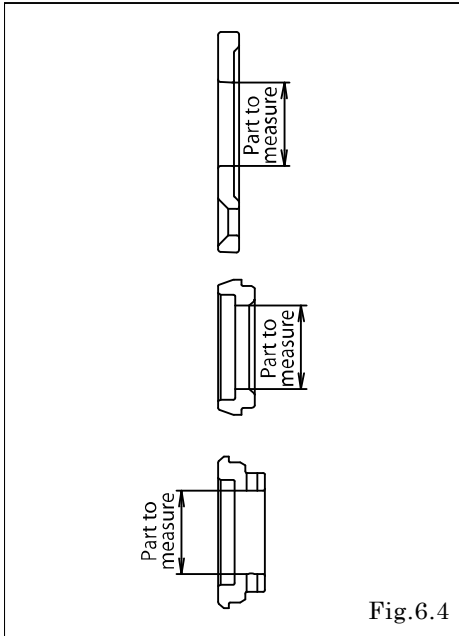

Fig. 6.4

- Guide bush stopper, guide bush A, guide bush B [Fig.6.4]  
Measure the inside diameter, and if it is outside the usable range, replace the guide bush stopper, guide bush A, guide bush B.

Usable range of guide bush stopper, guide bush A, guide bush B
$\varnothing 0.6299 - \varnothing 0.6496$ in { $\varnothing 16.0 - \varnothing 16.5$ mm}

## 6.3 Installation

For installation, see [Exploded View] on the separate sheet and install in the reverse order of disassembly.

### ■ P\_, V\_ Type

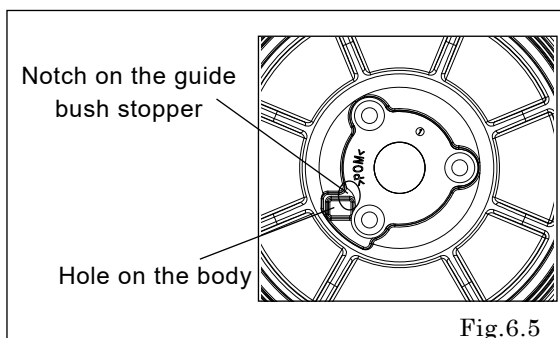

Fig. 6.5

Tightening torque for tapping screw	
P_, V	9 in-lbf {1.0 N-m}

<NOTE>

- Make sure there is no dust on the seal surface and the seal is not damaged.
- Apply grease to O ring.
- When installing the guide bush stopper, please place its notch to the hole on the body side. [Fig.6.5]

## 7. Spool assembly and Sleeve

### 7.1 Removal

#### ■ A\_, S\_ Type

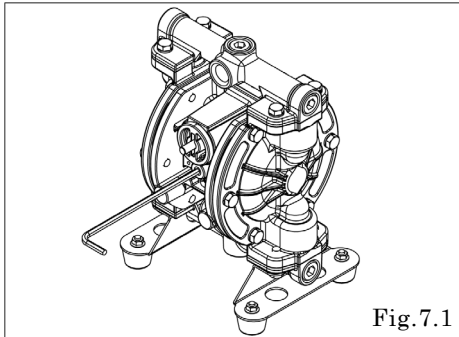

- Loosen the plug with hexagonal box wrench and remove remaining air from inside the pump. [Fig. 7.1]

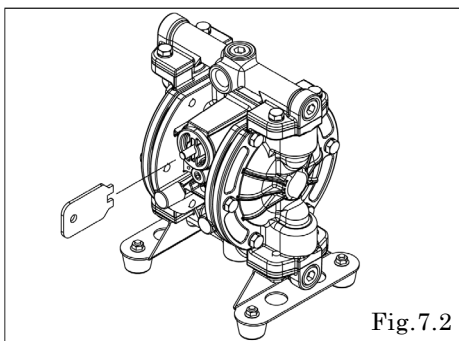

- Remove the cap A and cap B using the cap remover. (special tool: Part No. 717114). [Fig. 7.2]

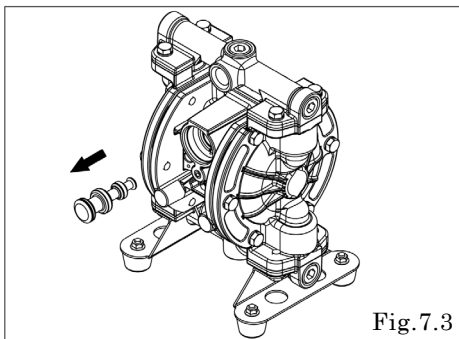

- Remove Spool assembly by pushing it from Cap A side (the side without reset button). [Fig. 7.3]

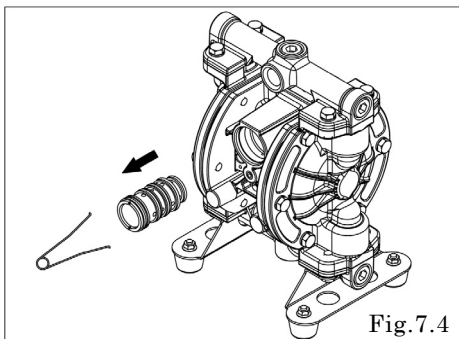

- Remove the sleeve using the sleeve remover (special tool: Part number 713148). [Fig. 7.4]

■ P\_, V\_ Type

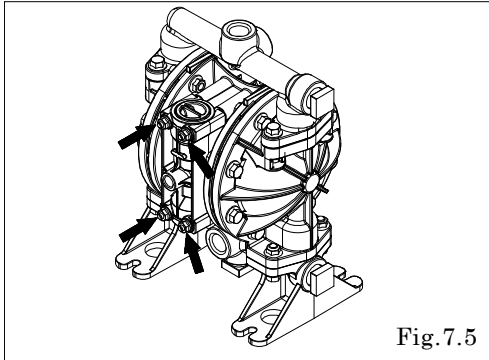

- Remove 4 nuts fixing the valve body assembly and draw out the valve body assembly from the main body. [Fig.7.5]

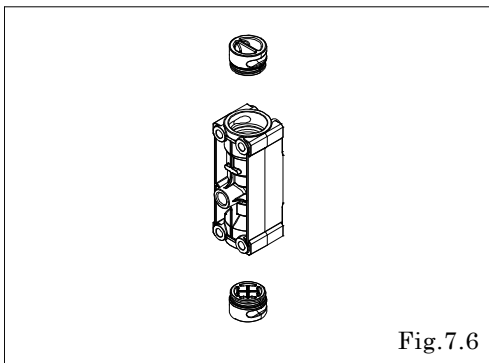

- Draw out the cap using the Pliers. [Fig.7.6]

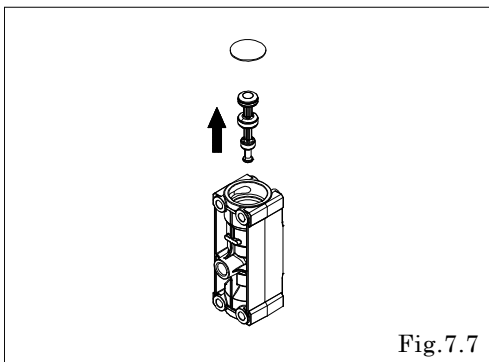

- Remove the cushion, and then push out the spool assembly from opposite side. [Fig.7.7]

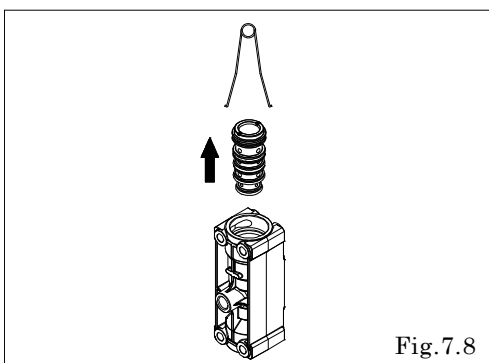

- Remove the sleeve using the sleeve remover (special tool: Part number 713148). [Fig.7.8]

## 7.2 Inspection

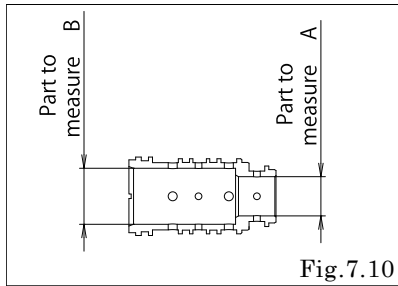
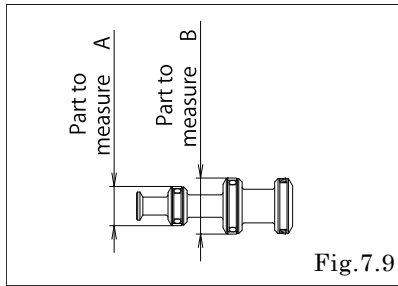

### Spool assembly

#### Seal ring [Fig.7.9]

Close the diagonal slit and measure the outside diameter, and if it is outside the usable range, replace the spool assembly.

If the Seal ring is worn out or cracked, replace spool assembly.

#### Usable range of Seal ring

A_, S_	Part to measure A	ø0.6909 in and over {ø17.55 mm and over}
	Part to measure B	ø0.9862 in and over {ø25.05 mm and over}
P_, V_	Part to measure A	ø0.4953 in and over {ø12.58 mm and over}
	Part to measure B	ø0.7039 in and over {ø17.88 mm and over}

### Sleeve [Fig.7.10]

Measure the inside diameter, and if it is outside the usable range, replace the sleeve.

#### Usable range of Sleeve

A_, S_	Part to measure A	ø0.6909 - ø0.6937 in {ø17.55 - ø17.62 mm}
	Part to measure B	ø0.9862 - ø0.9890 in {ø25.05 - ø25.12 mm}
P_, V_	Part to measure A	ø0.4984 - ø0.5016 in {ø12.66 - ø12.74 mm}
	Part to measure B	ø0.7055 - ø0.7087 in {ø17.92 - ø18.00 mm}

### O ring, Packing

If the O ring is worn out or cracked, replace it.

### <NOTE>

- Spool assembly and Sleeve must be replaced complete set. Unable to replace individual component.

## 7.3 Installation

For installation, see [Exploded View] on the separate sheet and install in the reverse order of disassembly.

### ■ P□, V□ Type

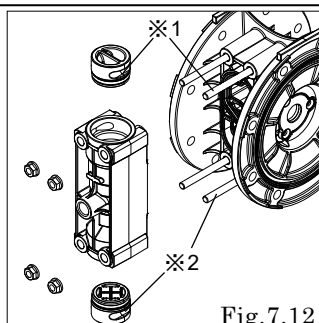
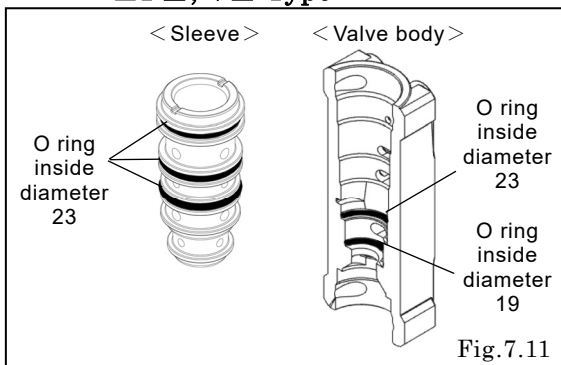

#### Tightening torque for valve body assembly attaching nuts

P_, V_	9 in-lbf {1.0 N-m}
--------	--------------------

### <NOTE>

- Make sure there is no dust on the seal surface and it is not damaged.
- Please place the O rings to the right positions on the outer surface of the sleeve. [Fig.7.11]
- Please insert the sleeve after putting the two O rings on the side of the valve body. [Fig.7.11]
- When embedding the sleeve into the valve body, please adjust the positions of the holes on the sleeve to the holes on the valve body. [Fig.7.11]
- When putting the caps on, please ensure that the dents on the caps, the holes on the valve body and the bolt holes are on the same positions. [Fig.7.12]

## 8. Retightening of Tie rods

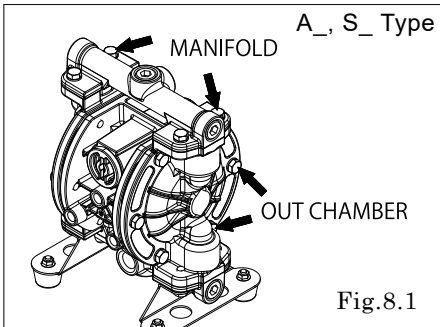

- The torque should be applied on the occasion of
  - (1) Right before the pump to use.
  - (2) There are any leaks of material on daily inspecting a pump.

	Retain bolts for the out chamber	Retain bolts for the manifold
AN, AH, AS, AT SN, SH, SS, ST	105 in-lbf {12 N-m}	105 in-lbf {12 N-m}
P_, V_	89 in-lbf {10 N-m}	89 in-lbf {10 N-m}

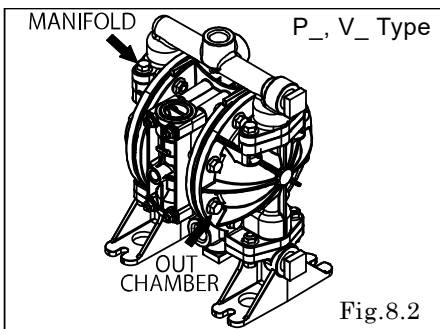

### <NOTE>

- Retighten the Out chamber and then the manifold in this order. [Fig. 8.1, Fig. 8.2]
- Please tighten the bolts in diagonal pattern. At this point, please firstly fasten all the bolts evenly to a certain extent, and repeat a few fastening rounds with the even force before finally tightening to the specified torque. [Fig. 8.3]
- When retightening the two bolts in upper position of one of the out chamber, please use a torque wrench with a spanner-shaped edge. [Fig. 8.4]

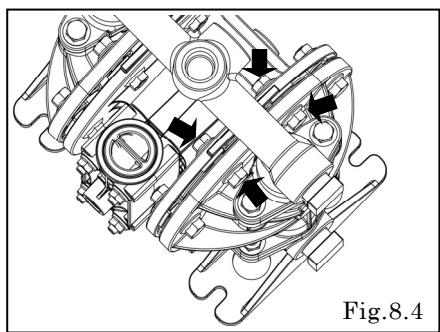
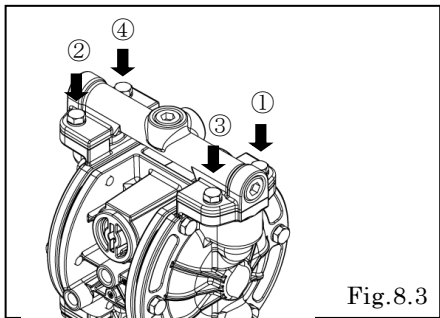





## **YAMADA AMERICA, INC**

955 E. ALGONQUIN RD., ARLINGTON HEIGHTS, IL 60005, USA

PHONE : 1-847-631-9200 or 1-800-990-7867 (Toll Free)

FAX : 1-847-631-9273

E-mail : [sales@yamadapump.com](mailto:sales@yamadapump.com)

Web : [www.yamadapump.com](http://www.yamadapump.com)

**Manufactured by:**

## **YAMADA CORPORATION**

International Department

1-1-3, Minami-Magome, Ota ku, Tokyo, 143-8504, Japan

PHONE : +81-(0)3-3777-0241

FAX : +81-(0)3-3777-0584

E-mail : [intl@yamadacorp.co.jp](mailto:intl@yamadacorp.co.jp)

Web : [www.yamadacorp.co.jp](http://www.yamadacorp.co.jp)

202302.2710 NDP497M